



2-20DTMKIII

Version 1.1



EC DECLARATION OF CONFORMITY
in accordance with Appendix II sub A of Directive 2006/42/EC

BLASTRAC B.V.
Utrechthaven 12
NL - 3433 PN NIEUWEGEIN
Tel: 0031 (0)30 601 88 66
Fax: 0031 (0)30 601 83 33
Info@Blastrac.nl
The Netherlands

Declare under our sole responsibility that the machine as described below
Conforms with the Health and Safety requirements of the European Directive
of the machine Safety.

In case of changes to the machine without our written authorization this declaration loses
its validity.

Model: **BLASTRAC 2-20DT** **Serial number:**

1. satisfies the conditions set out in the Machine Directive (Directive 2006/42/EC);
Low voltage directive (2006/95/EC, as last amended; EMC directive 2004/108/EC,
as last amended)
2. satisfies the following harmonized standards:
NEN-EN 349, NEN-EN 418, NEN-EN 294 and NEN-EN 60204

Nieuwegein



Michiel Kalisvaart

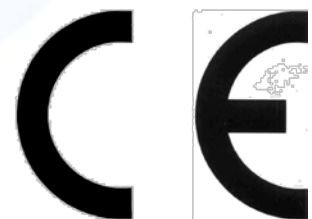

Table of contents

EC Declaration of Conformity	02
1. Introduction	04
2. Machine description	04
3. Safety	05
Safety precautions	
Safety regulations	
Safety instructions	
4. Initial operation	07
Checkpoints power supply	
Checkpoints of machine	
5. Operating	08
6. Maintenance	09
7. Selection of abrasive	10
8. Technical data	11
Contact	12

1. Introduction

It is important that all persons who are working with or maintaining this machine must read the manual carefully and understand it fully. Keep this manual near to the machine for reference.

Only authorized and trained personnel may operate this machine.

2. Machine description

The **Blastrac** blast cleaning machine 2-20DT is a downward blasting machine with a closed abrasive circuit designed for the pre-treatment of horizontal surfaces. The bouncing impact of metallic abrasive onto the surface to be treated thoroughly removes surface contaminants, coats of paint, sealants and thin coatings.

A suitable filter unit must be connected to the machine in order to separate the dust from the abrasive. A specially designed dust collection system ensures dust-free operation of the machine and clean air at the workspace.

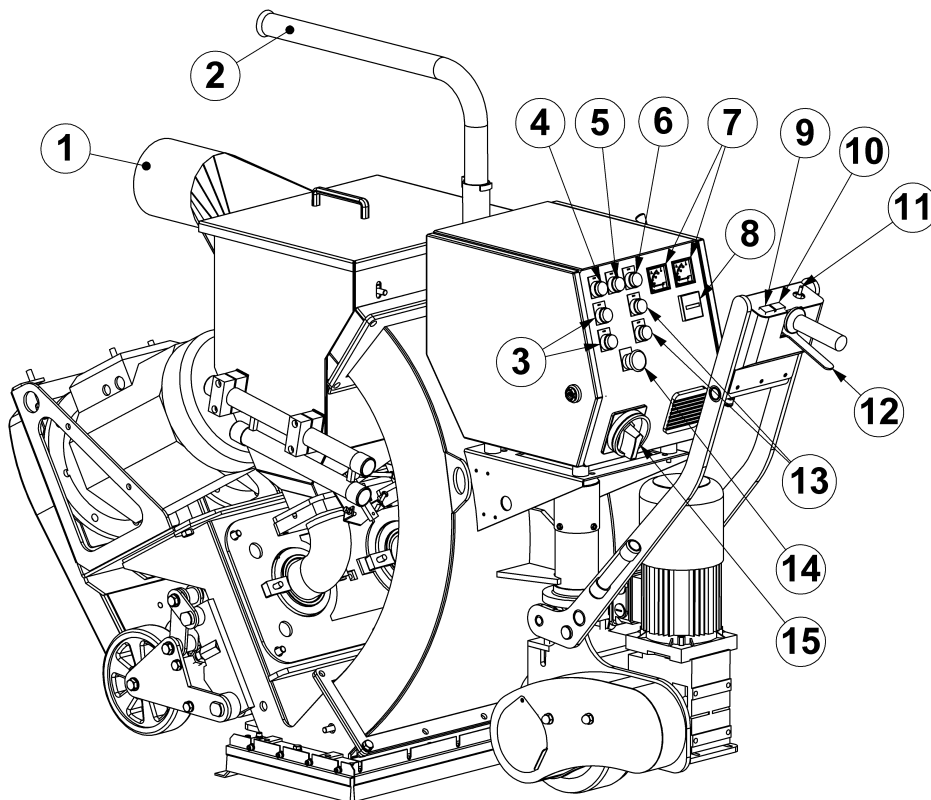

- | | | |
|-----------------------------------|-------------------------------------|----------------------------|
| 1 Connection pipe for dusthose | 6 Control lamp BLASTMOTORS ON | 11 Speed control |
| 2 Cable guide | 7 Ammeters left & right blast motor | 12 Travel switch |
| 3 Drive control ON and OFF | 8 Hour counter | 13 Blast motors ON and OFF |
| 4 Control lamp CONTROL VOLTAGE ON | 9 Overdrive | 14 Emergency shutdown |
| 5 Control lamp FAULT | 10 Move forwards | 15 Main switch |

3. Safety

Before operating the machine, the personnel must be familiar with the safety instructions given in this manual.

Keep this manual near to the machine for reference.

Safety precautions

- The surface to be treated must be swept clean to remove stones, screws etc.
- Never use the machine when the surface is not clear and if there is a risk of tripping.
- Make sure there is not any water on the surface to be treated.
- Don't get disturbed during the activities.
- Remove any trailing electrical cables and or dust hoses from the surface to be treated.
- Always switch on the dust collector.

Safety regulations

- Persons who are not operating the machine must not be permitted to stay in the surrounding area of the machine.
- Do not change anything on the machine. Always use cables which are approved and grounded. The machine should always be equipped with a grounded connection, do not change this and always use grounded plug.
- Inspect and test the electrical components regularly. The electrical components have to meet the requirements which apply to these components.
- Always call a skilled electrician or your distributor when you have questions about the safety of the electrical components.
- Work on electrical equipment or operating materials may only be undertaken by a skilled electrician or by authorized persons under the guidance and supervision of a skilled electrician as well as in accordance with safe electrical work practices.
- Always place the machine into maintenance mode prior to inspections and repairing on the machine as noted in bold type below.
- Never operate the machine when the surface is wet.
- Never operate the machine in the rain.

BEFORE BEGINNING TROUBLESHOOTING OR MAINTENANCE WORK ON THIS EQUIPMENT:

- 1. All power sources (Electrical, Pneumatic, and Mechanical) of energy must be locked off, tied off or otherwise neutralized to be considered harmless, no machine function will operate.**
- 2. It is important that operators and maintenance personnel receive regular equipment safety training,**
- 3. AND have a thorough working knowledge of all electrical, pneumatic and mechanical aspects of this equipment and observe all warnings and precautions.**

WARNING: Only qualified personnel should perform maintenance or troubleshoot this equipment.

The following sticker is placed on the machine.



Meanings of these symbols are:

- Ear protection is obliged
- Safety glasses with lateral protection are obliged
- CE-mark on this machine
- Safety shoes obliged
- Consult the manual before operating the machine

Personnel must tie back long hair and not wear loose clothing or jewellery including rings. Wear gloves and dust mask during operating the machine.

Safety instructions

- Abrasive can escape from the sides of the blast head at high speed. Wear safety glasses with lateral protection and close-fitting protective clothing.
- Be very careful when inserting the quick release pin
- The machine and especially the handle grip must be free of grease and oil, and must be dry.
- The dust container / bag of the filter unit must be emptied regularly. Comply with the local waste treatment regulations considering the removed material.
- The weight of the 2-20DT is 575 kg / 1,267 lbs. When transporting the machine with a crane or lift, use the lifting eyes on the machine.
- Pay attention that the drive unit does not turn away during lifting of the machine.

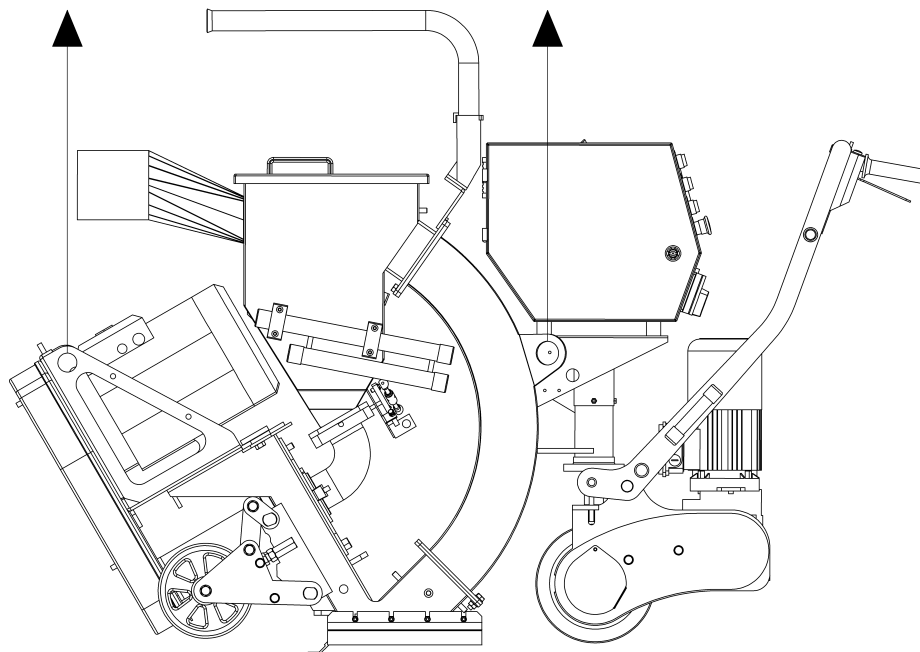

4. Before operation

Before using the machine it is of great importance to inspect the machine. It is not permitted to use the machine if the machine safety is not according to the checkpoints below.

Checkpoints powersupply

- Use only extension cables for extending the main cable that are sized and marked in accordance with the overall power consumption of the machine.
- Electrical cables must be rolled entirely off of the reels.
- Any damages to electric cables is not permitted, cables must be replaced.
- Use an electrical power supply connection with grounded connection.

Checkpoints of machine

- Safety functions and operating functions must work correctly.
- Check the following parts for damage and wear: blastwheel, feedspout, liners, magnet- and brush sealing.
- No loose bolts and nuts permitted
- No damage of electrical components permitted.
- Dust hose must be undamaged and the connection must be reliable.
- Check parts of the separator for wear and defects. Remove foreign bodies and dust deposits.



5. Operating

During operation of the 2-20DT, the following additional safety instructions must be followed closely.

Before switching on

- Check if the distance from magnet to the floor is 8 – 10 mm / ¼-3/8 inch. Check this height with aluminum strips.
- Check the distance from brush sealing to the floor. This may be max. 1 mm / .04 inch.
- Fill the separator equally with the selected abrasive up to the bottom of the separator tray. The magnetic valve must be closed while doing this.
- Connect the blast machine and dust collector with the dust hose. This connection must be reliable.
- Connect the power supply cable of the dust collector to a generator, or house power supply. Be sure that electrical power supply is correct.

Switching on the machine

- Switch on the dust collector first, then switch on the blast machine.
- Press the green push button "Blast wheels ON" and check the rotating direction of the blast motor. The correct direction is given with a arrow on the housing of the motor.
- Select the speed using the speed control knob. (item 11 of machine description)
- When the machine is traveling pull the abrasive control cable to open the magnetic valve. Observe the ammeter it may indicate the full load amperage. After having blasted aprox. 2 m / 6 ft., close the abrasive valve, stop the machine and check the blasted surface.
- If the 'hotspot' is too much on the right, turn the control cage clockwise in 1/8" increments until the desired pattern is achieved. Never adjust the control cage during blasting.

Switching off the machine

- Close the abrasive valve.
- Press the red button "Blast wheels OFF".
- Switch the blast machine main switch to "OFF" position.
- Refer to "maintenance mode" in chapter 3, page 5.
- Pull out the connector of the main power supply of the machine.
- Switch the dust collector's main switch to "OFF" position.
- Wait for all moving parts to completely stop before any inspection or maintenance work is performed.

6. Maintenance

Changing the liners

- Loosen the press bolt of the top liner and remove the cover.
- Loosen the nuts of the side liners and plenum liners. Remove them out of the bottom of the housing.

To install the liners, use the following sequence:

- First place the plenum liners and tighten them with the nuts.
- Place the side liners inside the housing. The sideliners should protrude 1/16" from the bottom of the blast housing. Tighten the nuts.
- Place the top liner in the housing and make sure that the top liner sits close to the edges of the side liners.
- Place the cover and tighten the bolts.
- Tighten the pressure bolts of the top liner slightly this will press the top liner against the side liners.

Changing the tune-up kit

The tune-up kit consists of the blastwheel, the control cage and a bolt.

- Remove the feed spout
- Remove the control cage clamps
- Remove the control cage and blastwheel cover plate
- Block the blastwheel with a block of wood or wooden hammer handle and remove the blast wheel bolt
- Remove the blastwheel out of the housing

Use a new blastwheel bolt when mounting a new blastwheel

- Place the blastwheel on the hub, carefully aligning the two recesses on the wheel with the dowel pins on the hub and tighten the central fixing bolt.
- Fix the blastwheel cover plate with 4 nuts
- Insert the control cage in the center and clamp the cage with the control clamps so that the blastwheel can rotate freely
- Turn the blastwheel manually. It must rotate freely.
- Place the feed spout between the abrasive valve and the cage.

Clean the machine every day with air and non-aggressive materials. Never use high pressure water to clean the machine.

Store the cleaned machine in a dry room. Protect the electrical motor from moisture, heat dust and shocks. Remove the abrasive out of the abrasive storage hopper.

All repair work has to be done by qualified Blastrac personnel; this will guarantee a safe and reliable machine.

Any guarantee on the machine is expired when:

- By not using original Blastrac spare parts and abrasive.
- When repair work is not done by qualified Blastrac personnel.
- When changes, add ons or conversions are undertaken without written permission of Blastrac.

7. Selection of abrasive

Media No. 2

Is often used when the surface is only subsequently sealed.

- creates fine profiles, e.g. on vacuum concrete and non-glazed tiles
- removes thin layers of rust on steel surfaces
- removes thin layers of paint

Media No. 3

- creates a fine to medium texture on concrete.
- removes glazing from tiles prior to subsequently coating with antiskid floor sealings
- removes old impregnations and coatings about 1 mm thick

Media No. 4

Standard abrasive, suitable for about 50-60 % of all applications. Creates a medium profile on concrete. Fulfills the same purpose as Media No. 3 when a higher speed of the machine is required, e.g. on asphalt, in order to keep the thermal load low.

- removes laitance from new concrete
- roughening of smooth concrete or natural stone
- removes coatings with a thickness of 1-3 mm
- cleaning of steel surfaces

Media No. 5

This media is used to create a coarse profile or to increase the work speed in the case of surfaces hard to treat.

- removes sediments on concrete prior to coating
- removes thick paint coatings or rust from steel surfaces, bridges, tanks, etc.
- removes flexible coatings on parking house decks
- removes road markings and retexturing of asphalt and concrete roads

Media No. 8

Only as an addition to Media No. 3, No. 4 and No. 5 with maximum 30% content.

Media No. 8 should never be used without blending since otherwise the wear in the machine as a whole would increase disproportionately.

- removes polyurethane coatings
- removes adhesive remnants
- removes rubber deposits
- penetrates coatings hard to remove
- also suitable to be used on steel for extraordinary roughness

8. Technical data

	2-20DT
Power consumption blast motor	22KW
Electrical connection (voltage is given on the control box)	480V / 60Hz / 3 Phase
Blast width	550 mm / 21.6 inch
Drive speed	0 – 33 m/min / 0-108 ft/min
Length	1950 mm / 6.4 ft.
Width	720 mm / 28 inch.
Height	1400 mm / 4.6 ft.
Weight	575 kg / 1,267 lbs.
Noise level (under load)	83dBa
Vibration level	1.9 RMS Allows 13,9 hrs. of working with the mentioned equipment without having to use anti vibration precaution measures.
Dust hose connection	Ø150 mm / 6 inch.

The electrical diagrams of the electrical system are placed inside of the control panel.

Design and specifications are subject to change without notice by Blastrac.

Blastrac

13201 North Santa Fe Avenue

Oklahoma City, OK 73114

Tel: 800-256-3440

Fax: 405-478-8608

www.Blastrac.com





2-20DTMK III

Version 1.3



Index

1. Spare parts	04
2. Contact	12



1. Spare parts

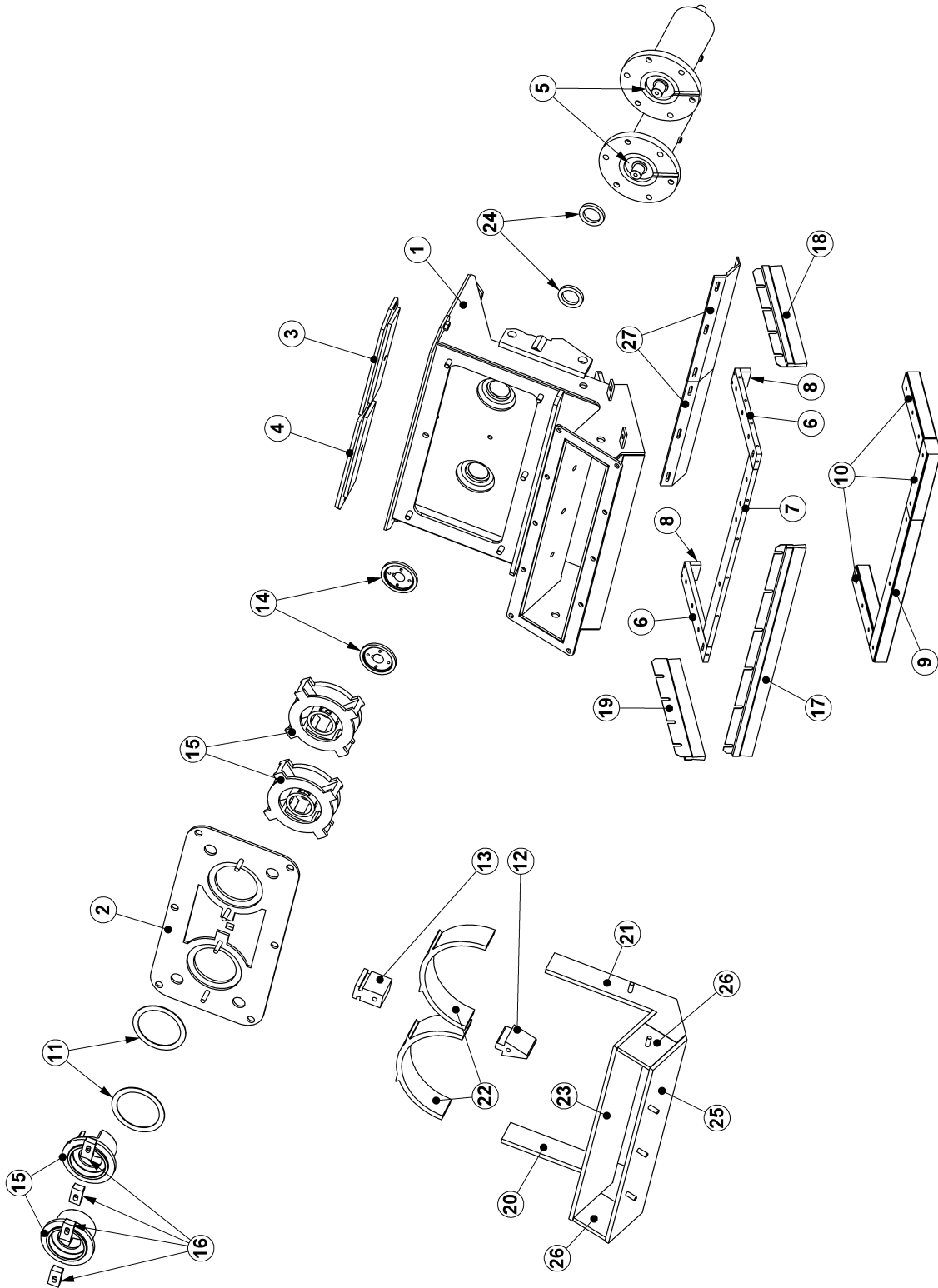

Fig. 01

Fig. 01

Item	Part number	Description	Remarks	Qty.
1	E03022	Blasthousing 2-20DT		1
2	P001667	Blastwheel cover plate	B21317	1
3	B21319	Blasthousing cover RH		1
4	P001485	Blasthousing cover LH	B21318	1
5	E00842	Bearing unit complete		2
6	489945	Insulator side		2
7	P001499	Insulator front	B21309	1
8	481350	Spacer side magnet rear		2
9	6940960	Magnet Front	B20804	1
10	PA-10644	Magnet side		3
11	9727810	Control cage shim		2
12	B21316-1	Centerliner bottom part		1
13	B21316-2	Center liner top part		1
14	B20397	Hub		2
15	B20536K	Tune up kit		2
16	969803	Control cage clamp		4
17	P001497	Front brush	B21330	1
18	E00457	Right side brush		1
19	E00458	Left side brush		1
20	P001464	Side liner LH	B21313	1
21	P001465	Side liner RH	B21312	1
22	B20325	Top liner		2
23	P001468	Plenum top liner	B21315	1
24	B20295	Felt seal Ø60x8		2
25	P001470	Plenum bottom liner	B21314	1
26	P001469	Plenum bottom side liner	970153	2
27	P001494	Skid seal	B21320	2

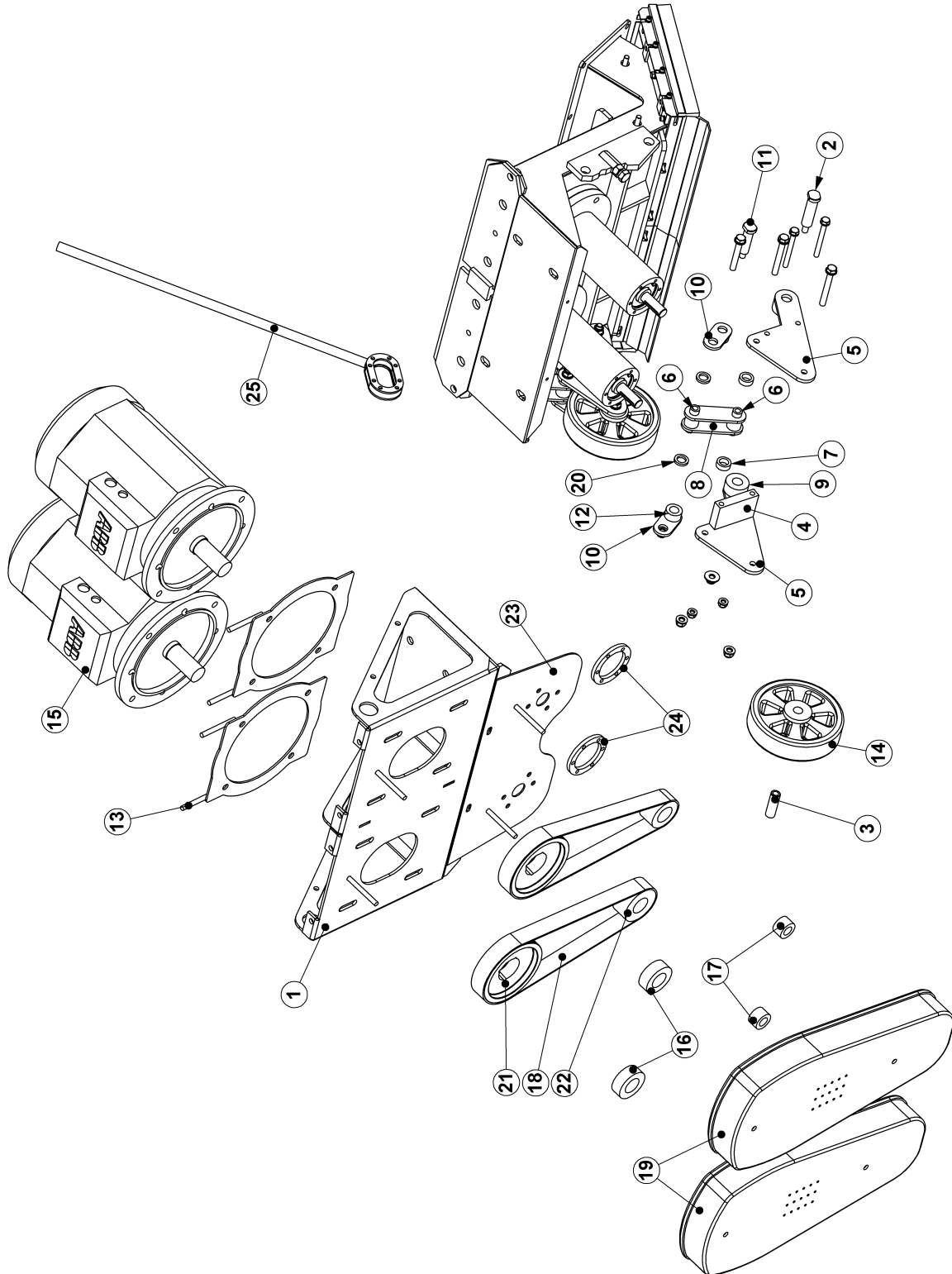

Fig. 02

Fig. 02

Item	Part number	Description	Remarks	Qty.
1	E00836	Motor bracket ABB twin		1
2	E06468	Bottom bolt		2
3	E06470	Idler wheel bush		2
4	E06475	Distance plate		2
5	E06465	Wheel bracket side plate		4
6	E06471	Lever shaft		4
7	E06473	Lever bush bottom		4
8	E06466	Bottom lever		4
9	E06472	Wheel bracket bush		4
10	E06467	Top lever		4
11	E06469	Top bolt		2
12	E06474	Lever bush top		4
13	E00769	Fill up plate blastmotor		2
14	B20842	wheel		2
15	E04642	Blastmotor 11 kW		2
16	DG15	Taper lock		2
17	976873	Taper lock		2
18	491522	Poly V belt	50Hz	1
	E00468	Poly V belt	60Hz	1
19	970168	Pulley guard		2
20	E06855	Lever bush middle		4
21	491523/1	Poly V pulley		2
22	2613-501	Poly V pulley (50Hz)	50Hz	2
	E00466	Poly V pulley (60 Hz)	60Hz	2
23	E00837	Back plate belt guard twin		1
24	E00864	Fill up ring bearing unit		2
25	B21917	Lever		1

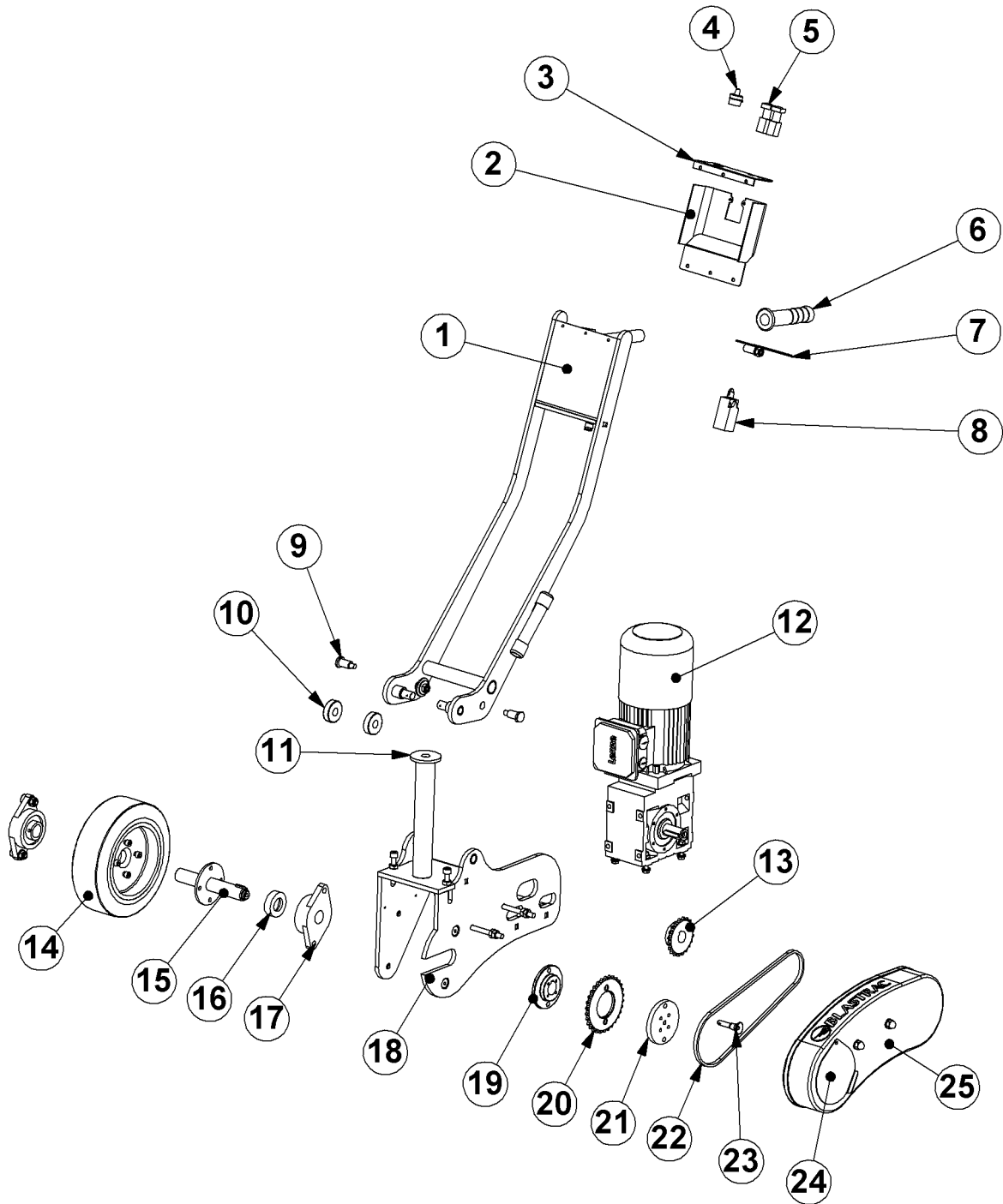

Fig. 03

Fig. 03

Item	Part number	Description	Remark	Qty.
1	E00737	Handle		1
2				
3				
4	E00866	Potentiometer complete (consists out of item 4.1 & 4.2)		1
4.1	E00866/1	Potentiometer only with soldered contact block		1
4.2	E00866/2	Potentiometer holder		1
5	E00867	Switch		2
6	453290	Handle grip		1
7	E00743	Switch lever		1
8	454796	Limit switch		1
9	E00738	Handle pin		2
10	B20517	Bearing		2
11	971860	Washer for yoke shaft		1
12	E00646	Drive motor		1
13	E00732	Sprocket		1
14	476405	Traction wheel		1
15	E00742	Drive wheel shaft		1
16	E07293	Distance bush drive wheel		1
17	009324	Bearing drive wheel		2
18	E00739	Drive wheel bracket		1
19	4885510-EU	Hub		1
20	4776310-EU	Idler sprocket		1
21	477630	Sprocket retainer		1
22	E00237	Chain		0.9m
22.1	E00238	Chain link		1
23	4781980	Quick release pin		1
24	9799710	Cover plate chain guard		1
25	E00744	Chain guard		1

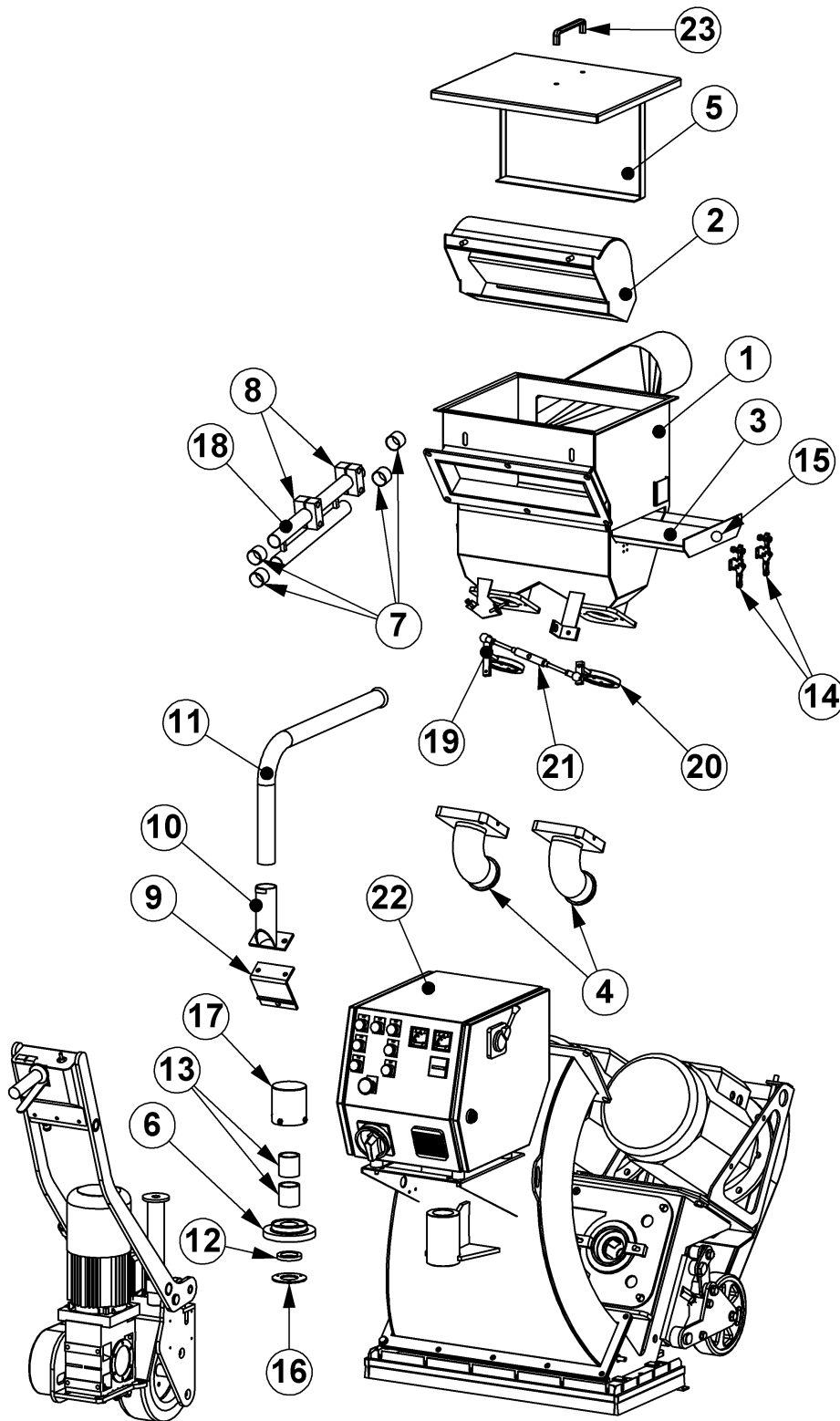
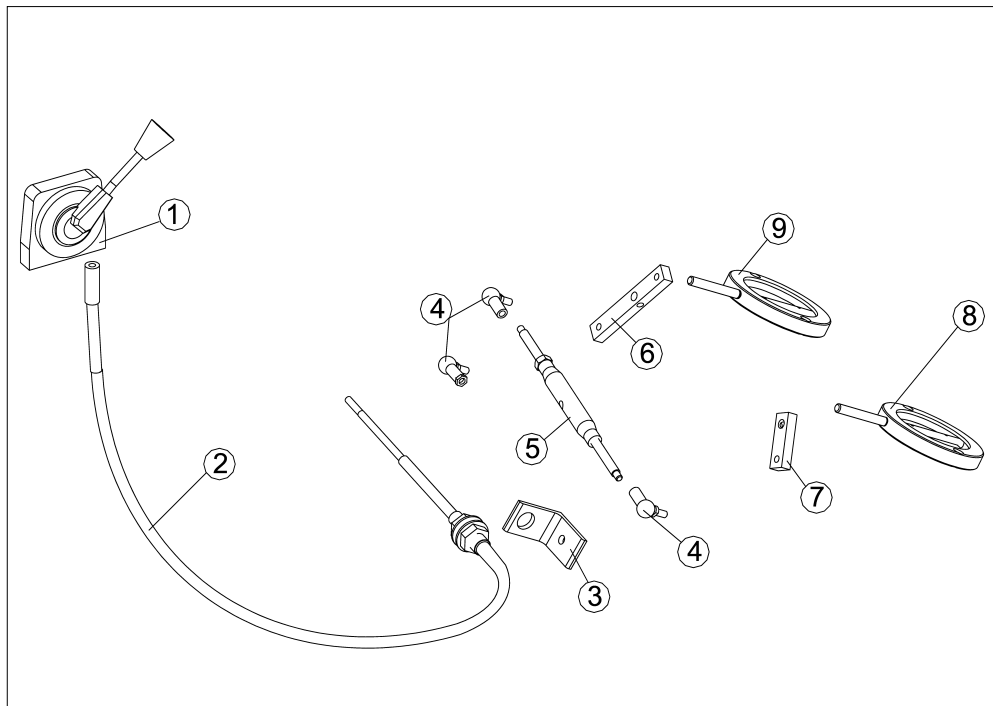

Fig. 04

Fig. 04

Item	Part number	Description	Remarks	Qty.
1	B21303	Separator		1
2	P001473	Deflector	B21297	1
3	P001474	Separator tray	B21304	1
4	6940900	Feed spout		2
5	B20263	Separator cover		1
6	P001461	Lifting plate	B20511	1
7	E00337	Cable protection cap		4
8	B21338	Pipe clamp.35mm (set of 2)		2
9	979994	Cable pillar bracket		1
10	B20426	Cable guide support		1
11	B20425	Cable guide		1
12	B20295	Felt seal		1
13	6940890	Oilite bush	971341	2
14	001084	Clamp for separator tray		2
15	B21325	Ball head for separator		1
16	P001463	Seal retainer	B20512	1
17	B20515	Shaft cover		1
18	E00839	Cable guide twin & cable adaption plate		1
19	B21295	Magnetic valve assembly		1
20	B21295R	Magnetic valve assembly		1
21	P001677	Turnbuckle	B21329	1
22	E00652/UL	Electrobox 2-20DT MKII		1
23	970385	Handle		1



Item	Part number	Description	Remarks	Qty.
1	B20519	Lever for control cable		1
2	6940930	Control cable	B22008	1
3	P001675	Hold angle	B21327	1
4	P001676	Angle joint	COZ9/1	3
5	P001677	Turnbuckle	B21329	1
6	B21326	Lever magnetic valve long		1
7	P001477	Lever magnetic valve	B21296	1
8	B21295R	Magnetic valve assembly		1
9	B21295	Magnetic valve assembly		1

Blastrac

13201 North Santa Fe Avenue

Oklahoma City, OK 73114

Tel: 800-256-3440

Fax: 405-478-8608

www.Blastrac.com





13201 North Santa Fe Avenue • Oklahoma City, OK 73114 • Ph: 800-256-3440 • F: 405-478-8608 blastrac.com

Product Warranty

Standard Equipment Products:

Blastrac warrants its Blastrac Standard Equipment Products against defects in quality of material and workmanship, under normal and proper use for a period of **1 Year** from the date of delivery, as noted on the returned warranty registration card, or, in the case of **Rental Fleet Machines, 180 Days** from the date of assignment to Rental Fleet. This warranty is non-transferable and is extended to machines purchased and entered into the normal service of surface preparation by a recognized professional or qualified contractor. Blastrac makes this warranty only to the buyer who purchases the products directly from Blastrac or its Authorized Distributor. This warranty does not include expendable parts such as, but not limited to, blades, blast wheels, wear plates, liners, seals, and electrical components. All purchased parts utilized in the manufacture will be honored to the original manufacturer's specified warranty.

If the buyer does not return the warranty card or register the product online at www.blastrac.com within 30 days after taking delivery of Blastrac Standard Equipment Products, the warranty period is limited to 6 months from the date of delivery noted on shipping receipt.

Hand Tool Products:

Blastrac warrants its BLASTRAC Hand Tool Products, including hand grinders and accessories, against defects in material and workmanship under normal and proper use for a period of **90 days** from the date of delivery or, in the case of Rental Fleet Machines, from the date of assignment to a Rental Fleet. Blastrac makes this warranty only to the buyer who purchases the products directly from Blastrac or its authorized distributor. This warranty does not include expendable parts such as blades.

If the buyer does not return the warranty card, or register online at www.blastrac.com within 15 days after taking delivery of Blastrac Hand Tool Products, the warranty period is limited to 30 days from the date of delivery noted on shipping receipt.

WARRANTY TERMS AND CONDITIONS:

1. Blastrac's obligation under this warranty is limited to the replacement or repair, at Blastrac's option, of products and does not include, labor, the cost of transportation, loss of operating time, or normal maintenance services.
2. This warranty does not apply to failure occurring as a result of abuse, misuse, negligence, corrosion, erosion, normal wear and tear, alterations or modifications made to products without the express written consent of Blastrac.
3. The buyer must submit all warranty claims no later than thirty (30) days after buyer becomes aware of the basis for any such claim, or should have become aware of the basis for any such claim in the exercise of reasonable diligence.

To return parts for warranty consideration, please call Blastrac Customer Service at **800-256-3440**. Your customer service representative will obtain the necessary information to complete the Blastrac Returned Merchandise Authorization (RMA) Form. Blastrac will then send the RMA form to the customer authorizing the return of the parts for warranty evaluation. The parts must be received within sixty (60) days following the RMA origination date or the warranty claim will be denied. Once the parts are received they will be evaluated for warranty.

If the customer cannot wait for the evaluation/replacement of the parts during this process, the customer must issue a new purchase order to Blastrac for the replacement parts before they can be shipped. Once the evaluation process is complete and parts are deemed a valid warranty claim, a credit will be issued against this invoice.

4. The buyer may not return Blastrac products without written authorization to do so through a Blastrac RMA.

5. Blastrac reserves the right to inspect and determine the scope of its warranty responsibilities for any returned Blastrac products.

6. Blastrac makes no warranty with respect to accessories it does not manufacture, including but not limited to, engines, motors, batteries, tires and all other parts. See component manufacture warranty.

7. Blastrac reserves the right to make product changes or improvements without prior notice and without undertaking any obligation for such changes or improvements on previously sold products.

8. The above warranty conditions can only be altered by Blastrac. Blastrac must confirm alterations in writing for each specific transaction.

9. Blastrac reserves the right to modify this warranty for used or demo products on an individual transaction basis. Blastrac will include warranty modifications on its invoices for used or demo products.

10. BLASTRAC DOES NOT AUTHORIZE ANY PERSON, REPRESENTATIVE, SERVICE OR SALES OUTLET TO MAKE ANY WARRANTY DIFFERENT FROM THIS PRODUCT WARRANTY.

11. EXCEPT FOR ITS PRODUCT REPAIR OR REPLACEMENT OBLGATIONS DESCRIBED IN THIS PRODUCT WARRANTY, UNDER NO CIRCUMSTANCES SHALL BLASTRAC BE LIABLE TO THE BUYER, OR ANY OTHER PERSON, FOR ANY DIRECT, INCIDENTAL, OR CONSEQUENTIAL DAMAGES RESULTING FROM THE USE OF THE BLASTRAC PRODUCT, OR FOR ANY SPECIAL OR CONSEQUENTIAL DAMAGES OF ANY CHARACTER, INCLUDING WITHOUT LIMITATIONS, DAMAGES FOR ANY LOSS OF GOODWILL, WORK STOPPAGE, OR ANY AND ALL OTHER COMMERCIAL DAMAGES OR LOSSES.

12. BLASTRAC MAKES NO OTHER PRODUCT WARRANTIES, EXPRESS OR IMPLIED, INCLUDING, BUT NOT LIMITED TO, THE IMPLIED WARRANTIES OF MERCHANTABILITY AND FITNESS FOR A PARTICULAR PURPOSE.



IMPORTANT!

TO THE DELIVERING DISTRIBUTOR OR END USER

To ensure the proper warranty coverage is extended to the owner of this machine, fill in the necessary information below **COMPLETELY** and **ACCURATELY** and retain for your records. **Go to www.blastrac.com and register online.** Click on the Register icon in the left column of the homepage, and fill out the product registration form with the same information that will be recorded here.

The warranty period will start upon the delivery date of the machine.

The distributor or the end user must provide the machine warranty information when the machine is delivered. Registration of the machine will extend the warranty period from the recorded delivery date entered with product registration. **Failure to comply will make any and all warranties on the equipment void after 6 months.**

OWNER/END USER'S REFERENCE INFORMATION

Delivery Date _____	Machine Model No. _____
Delivering Distributor's Name and Address _____	Machine Serial No. _____
_____	Modifications _____
_____	_____
_____	_____
_____	_____
_____	_____

Signature of Delivering Distributor's Representative

Blastrac is a registered trademark of Blastrac,NA
Fold and Detach Here if Mailing

Warranty Registration

IMPORTANT! To ensure that your Blastrac® machine is covered under warranty, please provide the information recorded here by registering online at blastrac.com, or complete this page and fax to 866-485-1046, or if you prefer, detach and mail to:

Blastrac, 13201 North Santa Fe Avenue, Oklahoma City, OK 73114-9901

(Please print legibly)

Company _____

Address _____

City, State, & Zip _____

Telephone No. _____ Contact Person _____

Date of Purchase _____ Date Received _____

Machine Model No. _____ Serial No. _____

Distributor Name _____

End User Name _____

End User E-mail _____